

3-point static

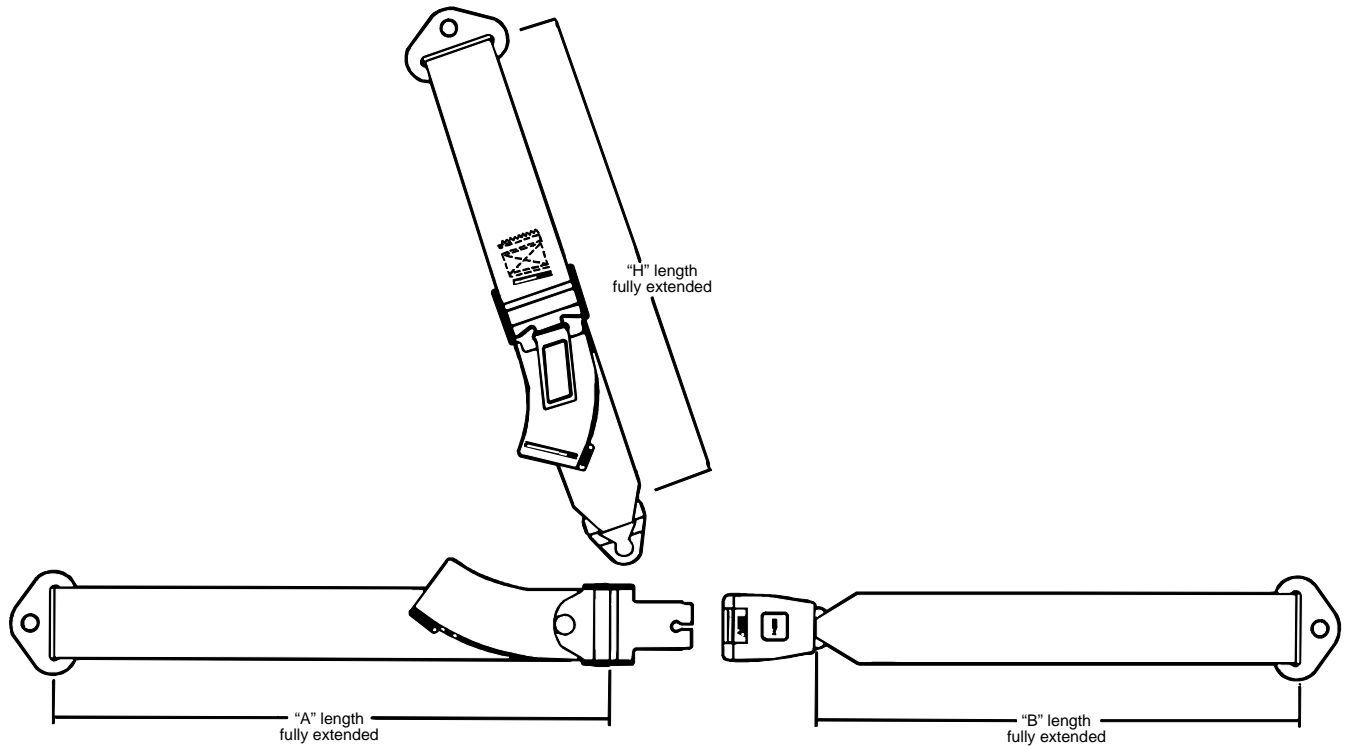

PART NO. SYSTEM

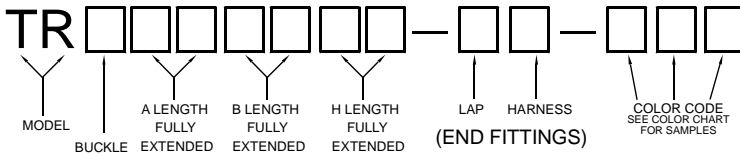







SAMPLE PART NO.
T R A 2 6 2 8 4 5 - E C - 0 1 2

The ABI Ultima can be used for any aviation application. Push button restraints have become especially popular in the business jet and general aviation marketplace due to limited space configurations in these aircraft and because they are easy to use.

A metal housing is available on this model to allow for decorative plating finishes. Contact ABI for additional information about this restraint system and available custom plating options.

Aircraft Belts
 2000 Anders Lane
 Kemah, TX 77565
 Phone 800.847.5651, Fax 281.538.2225
www.aircraftbelts.com

BUCKLE CODES		
CODE	P/N	DESCRIPTION
A	3/87	2-way Buckle (metal housing)
B	3/87	2-way Buckle (plastic housing)
C	3/87	2-way Buckle (metal housing without top push button window)
D	3/87	Ultima 2-way Buckle (metal housing)
E	3/87	Ultima 2-way Buckle (plastic housing)

ENDFITTINGS		
 4A	 4B	 4C
 4D	 4E	 4G

ENDFITTING CODES					
CODE	P/N	BOLT HOLE	CODE	P/N	BOLT HOLE
A	4A	.375 HOOK	D	4D	.386 HOLE
B	4B	.25 HOLE	E	4E	.406 HOLE
C	4C	.325 HOLE	G	4G	.386 HOLE

Choose Reel Code from Hardware Selection

- NOTES:
- Standard Buckle is plastic; plated metal finishes available.
 - Restraint assemblies conform to
 - Identification labels affixed to each portion of assembly.
 - Lap assembly rated to 3000 lbs; harness assembly rated to 2500 lbs.
 - Belt dimensions toleranced at +/- .5"
 - All folds are up with .50" tuck under.